

Amana[®]
Gas Range
Use & Care Manual

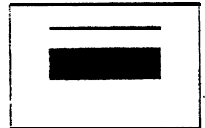

Model:
AGS780

CONTENTS

Important Instructions for Safe Cooking	3
Instatlation Information	6
Range Features	7
Electronic Oven Control	8
To Set Clock and Minute Timer	9
How To Start Rangetop Cooking	10
Baking	11
To Set Oven For Bake	11
To Set Oven For Time Bake	12
To Set Oven For Delayed Time Bake	12
Oven Temperature Adjustment	13
Broiling	14
Broil Chart	15
How To Clean The Rangetop	15
Self-Cleaning The Oven	17
To Set Self-Clean Cycle To Start Now	18
To Set Self-Clean Cycle To Start Later	18
Care and Cleaning Of Other Oven Parts	20
Removable Oven Door	20
Replacing The Oven Light	20
Replacing The Panel Light	20
Storage Drawer	21
Commonly Asked Questions	22
Before Calling For Service	23
When Service Is Required	23
Amana Toll Free - Consumer Information Line	23
Amana Asure	23

To insure safety for yourself and your home, please read your Use & Care Manual carefully. Keep it handy for quick, easy reference.

Pay close attention to the safety sections of your manual. You can recognize the safety sections by looking for the  symbol or the word "safety."

Record in the space below the Model No., Manufacturing (Mfg) No. and Serial No. found on the nameplate of your range. To locate the nameplate, open the oven storage drawer and look on right side. The nameplate is on the lower oven frame.

Model No. _____

Mfg. No. _____

Serial No. _____

Date Installed _____

Selling Dealer _____

Retain these numbers and your Sales Receipt for proof of purchase should warranty questions arise. Your Sales Receipt is required if warranty service is needed. Complete the registration card, which is included with the packet that comes with the range. This must be filled out and returned to Amana Refrigeration, Inc.

IMPORTANT INSTRUCTIONS FOR SAFE COOKING

As with all appliances, there are certain rules to follow for safe operation. Make sure everyone who operates this range is familiar with this product's operation and with these precautions.

CAUTION: TO AVOID PERSONAL INJURY OR PROPERTY DAMAGE FOLLOW THESE INSTRUCTIONS

FOR YOUR SAFETY

 **WARNING:** If the information in this manual is not followed exactly, a fire or explosion may result causing property damage, personal injury or death.

— Do not store or use gasoline or other flammable vapors and liquids in the vicinity of this or any other appliance.

— WHAT TO DO IF YOU SMELL GAS

- Open windows.
- Do not try to light any appliance.
- Do not touch any electrical switch: do not use any phone in your building.
- immediately call your gas supplier from a neighbor's phone. Follow the gas supplier's instructions.
- If you cannot reach your gas supplier, call the fire department.
- Extinguish any open flames.

— Installation and service must be performed by a qualified installer, service agency or the gas supplier.



CAUTION:

To Avoid the Risk of Personal Injury:
Do not store items of interest to children in cabinets above your rangetop — children climbing on the range to reach items can be seriously injured.

FOR YOUR SAFETY

DO NOT OBSTRUCT THE FLOW OF COMBUSTION AND VENTILATION AIR.

Know where your main gas shut off valve is located.



CAUTION:

Do not attempt to clean the oven or broiler burner ignitor assembly, the ignitors are electrically operated and the possibility of electrical shock is present.



FOR YOUR SAFETY

Do not store or use gasoline or other flammable vapors or liquids in the vicinity of this or any other appliance.

SAVE THESE INSTRUCTIONS

1. Top burners may be lit with a match. Do not use oven or broiler during electrical power outage (see instructions on page 9.)
2. For your safety, top burner flame size should be adjusted so it does not extend beyond the bottom edge of the cooking utensil.
3. The appliance must not be used for space heating.
4. Gas supply pressure max. 8 and min. 6 inch wcp for Natural gas. Max. 12 and min. 11 inches wcp for LP gases. The appliance pressure regulator is set at 5 inches wcp for Natural gas and 10 inches wcp for LP gases.
5. Do not store items on the rangetop during baking, broiling or self-cleaning since the oven vents over this area.

Surface Cooking Units:

1. Use Proper Pan Size — Select utensils large enough to properly contain food and avoid boilovers or spillovers. This will prevent hazardous accumulations of food (especially grease), since heavy splattering or spillovers left on a range can ignite. Pan size is especially important in deep fat frying.
2. Never Leave Surface Burners Unattended at High Heat Settings — Boilovers cause smoking and greasy spillovers which can ignite.
3. Glazed Cooking Utensils — Only certain types of glass, glass/ceramic, earthenware, or other glazed utensils are suitable for rangetop use. Some are not suitable and will break due to the sudden change in temperature.
4. Type of Utensils — Avoid pans that are unstable and tip easily. In choosing pans, look for easy-to-grip handles that will stay cool. Pans that are too heavy when filled with food can also be a hazard. If pan handles twist and cannot be tightened, discard the pan.

IMPORTANT INSTRUCTIONS CONT.

5. Utensil Handles Should Be Turned Inward and Not Extend Over Adjacent Surface Burners — To reduce the risk of burns, ignition of flammable materials, and spillage due to unintentional contact with the utensil, the handle of a utensil should be positioned so that it is turned inward, and does not extend over adjacent surface burners.
6. Do not mix household cleaning products. Chemical mixtures can interact with objectionable or even hazardous results.
7. Clean **rangetop** with caution. To avoid steam burns — do not use a wet sponge or cloth to wipe up spills on a hot cooking area.
8. Grease — Grease is flammable and should be handled carefully. Never leave any cooking operation unattended. Let fat cool before attempting to handle it. Do not allow grease to collect around the rangetop. Wipe up spills immediately,

Use this appliance only for its intended purpose as described in this manual.

1. Do Not Leave Children Alone — Children should not be left alone or unattended in area where appliance is in use. They should never be allowed to sit or stand on any part of the appliance.
2. Wear Proper Apparel — Loose-fitting or hanging garments should never be worn while using the appliance.
3. Use Only Dry Potholders — Moist or damp potholders on hot surfaces may result in burns from steam. Do not let potholder touch hot heating surfaces. Do not use a towel or other bulky cloth.
4. User Servicing — Do not repair or replace any part of the appliance unless specifically recommended in this manual. All other servicing should be referred to a qualified technician.
5. Storage in or on Appliance — Flammable materials should not be stored on or near surface burners.
6. Do Not Use Water on Grease Fires — Smother fire or flame with a nonflammable lid or use dry chemical or foam-type extinguisher.

Ovens:

1. Use Care When Opening Door — Let hot air or steam escape before removing or replacing food.
2. Do Not Heat Unopened Food Containers — Build-up of pressure can cause container to burst and result in injury.

3. Keep Oven Vent Ducts and Openings Unobstructed.
4. Placement of Oven Racks — Always place oven racks in desired location while oven is cool. If rack must be moved while oven is hot, do not let potholder contact hot oven or broiler burner in oven.

Self-Cleaning Ovens:

1. Do Not Clean Door Gasket — The door gasket is essential for a good seal. Care should be taken not to rub, damage, or move the gasket.
2. Do Not Use Oven Cleaners — No commercial oven cleaner or oven liner protective coating of any kind should be used in or around any part of the oven.
3. Clean Only Parts Listed in Manual.
4. Before Self-Cleaning the Oven — Remove oven racks, broiler pan and other utensils. Wipe up excessive spillage and grease.

Ventilating Hoods:

1. Clean Ventilating Hoods Frequently — Grease should not be allowed to accumulate on hood or filters.
2. When flaming foods under the hood, turn the fan off. The fan, if operating, may spread the flame.

A WARNING:
ELECTRICAL SHOCK HAZARD
The electrode of the spark igniter is exposed when the top of the burner is removed. The spark igniter sparks anytime a control knob is turned on and the gas from the burner is not ignited. Be careful not to push in any **rangetop** controls while the top of the burner is removed. Electrical shock might result.

⚠ WARNING:
This product contains or produces a chemical or chemicals which may cause serious illness or death and which are known to the State of California to cause cancer, birth defects or other reproductive harm.

FOR SAFETY'S SAKE

- Do not put plastic items on warm cooking areas, They will stick and melt.
- Do not use aluminum foil or place foods pack aged in aluminum foil directly on the **rangetop** for cooking. Use of foil can damage the rangetop.
- Do not leave fat heating unless you remain nearby. Fats can ignite if overheated by spilling onto hot surfaces.
- Do not allow pots to boil dry on high settings as this can cause damage to the **rangetop** surfaces and the pan.
- NEVER use your **rangetop** or oven for storage space.
- The broil and bake burners cannot be operated during a power failure and no attempt should ever be made to do so.

⚠ CAUTION: TO AVOID THE RISK OF BURNS:

DO NOT TOUCH SURFACE BURNERS, BURNER GRATES, OR AREAS NEAR BURNERS — Areas near surface burners can become hot enough to cause burns. During and after use, do not touch or let clothing or other flammable materials contact surface burners or areas near burners until they have had sufficient time to cool. Among these areas are the **rangetop** and the surfaces facing the rangetop.

DO NOT TOUCH BAKE OR BROIL BURNERS OR INTERIOR SURFACES OF OVEN — Bake and broiler burners may be hot even though they do not look hot. Interior surfaces of an oven become hot enough to cause burns. During and after each use, do not touch, or let clothing or other flammable materials contact bake or broiler burners or interior surfaces of oven until they have had sufficient time to cool. Other surfaces of the appliance can become hot enough to cause burns — among these surfaces are oven vent openings and surfaces near these openings, oven door, window of oven door, and oven racks.

RANGETOP GREASE FIRE

Never use wafer on a grease fire — it will only spread the flames.

Never pick up a flaming pan.. . Instead:

1. If possible, turn off the burner.
2. Smother the fire with a tightly fitting pan lid, baking soda or with a dry chemical or foam type extinguisher.



In case of grease fires:



A CAUTION:

Due to the Nature of Cooking, Fires can Occur as a Result of Overcooking, Excessive Grease, or Component Failure. Though a Fire is Unlikely, if One Occurs Proceed as Follows:

SURFACE BURNER FIRES

1. **DO NOT** turn on a range vent hood. The flames could be drawn into the hood where more damage could result.
2. Smother the fire with a **non-flammable** lid or baking soda, or use a Class "ABC" or "BC" extinguisher. Not water. Not salt. Not flour.
3. As soon as it is safe to do so, turn the surface burner controls to "OFF."

OVEN FIRES

1. If you see smoke from your oven, **do not open the door.**
2. Turn the oven controls to "OFF."
3. As an added precaution, turn off the power at the main circuit breaker or fuse box.
4. Turn on the range vent hood or exhaust fan, if you have one, to remove smoke.
5. Allow food or grease to burn itself out in the oven.

OF COURSE, IF SMOKE AND FIRE PERSIST, CALL THE LOCAL FIRE DEPARTMENT.

If there is any damage to components, call your repair service before using the range or **rangetop** again.

Remember, excessive grease is always a fire hazard. The best prevention is to keep your range and **rangetop** clean and free of excess grease.

INSTALLATION INFORMATION

For detailed instructions on proper installation, refer to the installation instructions included with the range.

You can install an optional vent hood ventilation system above your range. Consult your Amana dealer for more information about Amana vent hoods. Remember, it is important to clean a vent hood frequently to prevent the risk of fire.

TO INSTALL RANGE:



WARNING:

To Avoid the Risk of Electrical Shock, Personal Injury, or Death:

Your range must be properly grounded and installed by a qualified installer. It is the personal responsibility and obligation of the customer to contact a qualified **electrician/installer** and have the unit connected to a properly grounded circuit in accordance with the National Electric Code.

You can be assured, that your Amana range has been certified by the American Gas Association as being in compliance with safety standards established by the American National Standard Institute.

It is the responsibility of the installer to see that this appliance is installed in accordance with the recommended installation procedure.



CAUTION:

The range must be secured to the house structure. **Information** regarding anchoring is contained in the installation instructions and it is the responsibility of the installer to see that this appliance is installed in accordance with the recommended installation procedure. Anchoring is required in order to prevent tipping while subjecting the range to improper use.

Anti-tip brackets are included with your range. See instructions for complete details.



WARNING:

Improper installation, alteration, **service** or **maintenance** can cause injury **property** damage or death. **Refer to this manual.** For assistance or additional information **consult** a qualified installer, service agency, manufacturer (dealer) or the gas supplier.

A gas pressure regulator is supplied and must be installed when appliance is connected to gas supply.

The range is factory set for use with Natural Gas. If you wish to use L.P. Gas, detailed instructions are provided in the Installation Instructions. It is recommended by the manufacturer that the conversion be done by a qualified servicer.

TOP BURNER SETTINGS

Low burner flame may be adjusted by turning adjustment screw in center of valve stem. Normally, the low flame should be adjusted to the minimum steady blue flame. (Approx. 1/4" flame length.)

Check the adjustment by turning from high to low several times to see that the burner does not go out.

REMOVAL AND REPLACEMENT OF RANGE

If the unit must be removed at any time after installation, the following procedures must be followed:

1. Remove storage drawer (see page 21).
2. Shut off main gas supply valve to range.
3. Disconnect 120V. supply plug.
4. Disconnect the range from the main gas supply connection above the shut off valve mentioned in Step 2. It is essential that Step 2 has been carried out prior to disconnecting the supply from the range.
5. Your range is secured to the floor using (2) screws and an anti-tip bracket.
6. Slide range forward. When re-installing the range, follow the directions given in the Installation Instructions. See page 9 for instructions on setting the electronic clock.

NOTE: Slight smoking may occur when the oven is used for the first time. This is a normal condition.

RANGE FEATURES

Your gas range features an easy-to-use electronic clock and oven control. Not only does this control operate all timed baking and cleaning functions, it also controls the oven thermostat to give you precisely controlled baking and broiling. The sealed gas burners provide even heat distribution. The push-to-turn control knobs are designed with safety in mind to prevent accidental operation. The control knobs, burner grates and burner caps are removable for easy cleaning.

Your self-cleaning oven features the Insta-Broil™ broiling system and a deluxe broiler pan set. The oven window and oven light allow you to conveniently view food inside without opening the oven door. The two oven racks are adjustable to any of the five rack positions. The storage drawer is a handy place to store your cookware and is removable for convenience when cleaning under the range.

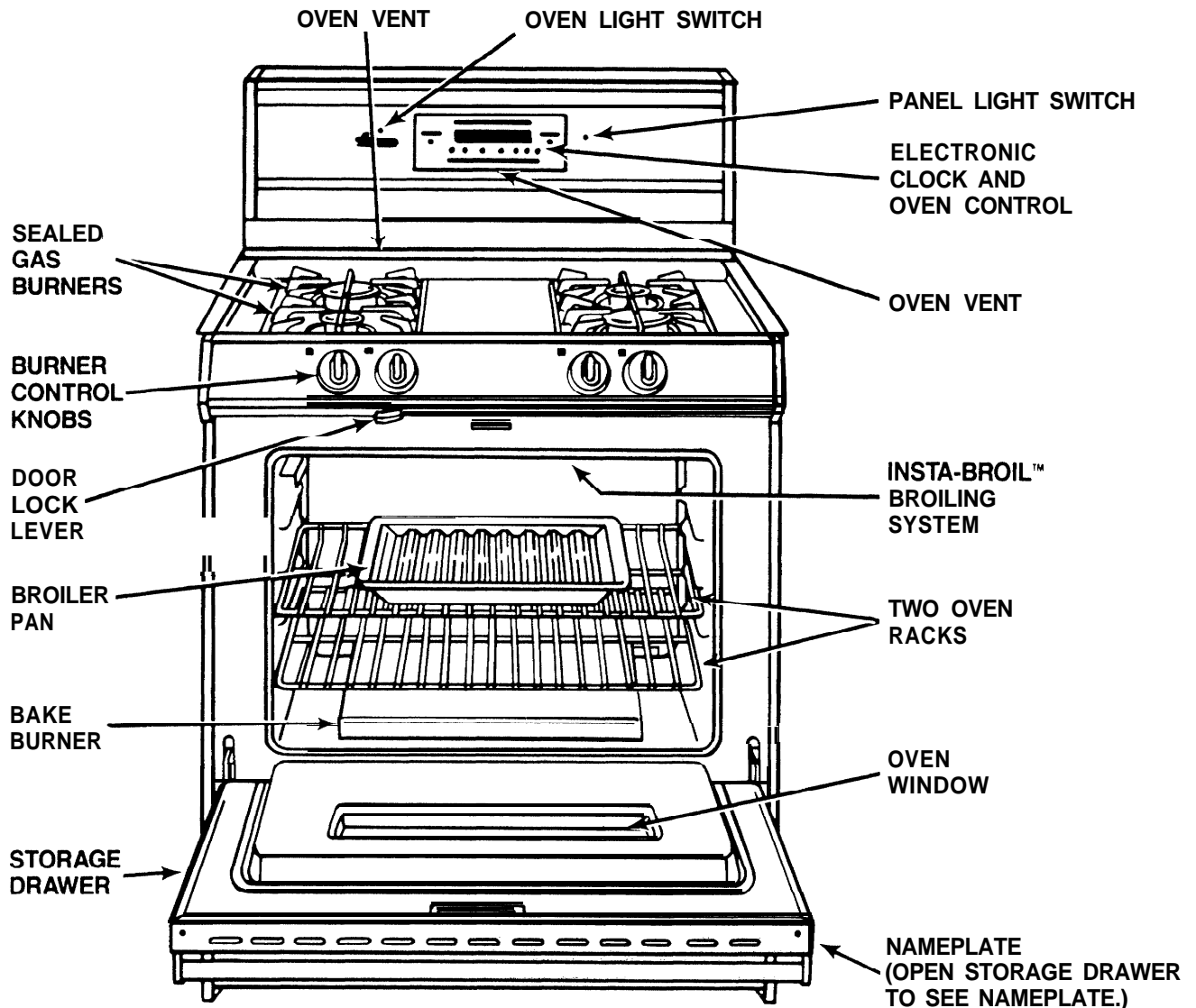

Burner Control Knobs are arranged to match the locations of the tangetop areas they control. Control knobs are push-to-turn, safety-type knobs. Push in and turn knobs counter-clockwise to the "LITE" position to light range surface burners and then turn clockwise to adjust the flame height.

Oven Light Switch: Use the oven light and oven window to check the progress of cooking. Doing this instead of frequently opening the oven door will help save energy and ensure even baking results. Oven light will turn on automatically when oven door is opened.

ELECTRONIC OVEN CONTROL

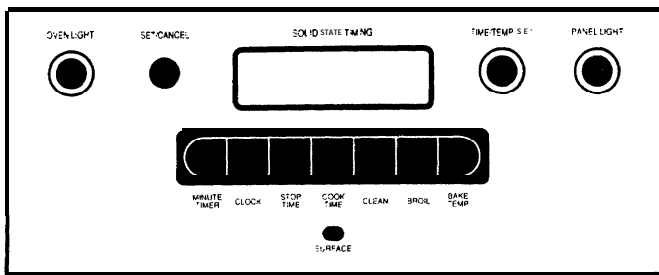

Your range features an easy-to-use electronic oven control. Not only does this control operate all timed baking and cleaning functions, it also controls the oven thermostat to give you precisely controlled baking and broiling.

Control Buttons

SET/CANCEL button — use to set clock or cancel programmed functions and turn oven off. Can be used to cancel mistakes or reprogram control,

MINUTE TIMER button — use to time **rangetop** cooking, oven baking, or other various kitchen activities.

CLOCK button — use to set the time of day.

COOK TIME button — use to set timed baking functions.

CLEAN button — use to set oven for self-clean cycle. See page 17 for self-cleaning instructions.

STOP TIME button — use to set delayed bake and self-clean operations.

BROIL button — use to program broil feature. See page 13 for broiling instructions.

BAKE TEMP button — use to set any of the bake operations.

TIME/TEMP SET knob — turn to select times and oven temperatures.

Each time these buttons are pressed, you will hear a **confirmation tone**, if this feature has been selected. This confirmation tone is optional and can be deactivated, if desired.

To deactivate the confirmation tone:

1. Push and hold the SET/CANCEL button. The button will beep once initially and then beep again after about three seconds. Release button. The confirmation tone is now cancelled.
2. To reactivate the confirmation tone, push and hold SET/CANCEL button until you hear one beep. The control buttons will now sound the tone each time any are pressed.

Display Features

The words and numbers in the control's display will light up to indicate which functions have been programmed.

The "ON" indicator will light up in the display when the bake and/or broil programs are selected.

The "ON" indicator will light up in the display when the bake and/or broil programs are active.

"BAKE," "BROIL" and "CLEAN" on the right hand side of the display will tell you which mode has been selected. "HR" will light up when timed feature is set for a certain number of hours.

Signal Tones

End of Cycle Tone — after a timed oven operation is finished, the oven will sound three long beeps. When the Timer feature is used, it will sound three long beeps and then it will beep once every ten seconds until the TIMER button is pushed.

Service Tones — the oven control will sound a series of short, rapid beeps and the display will show a diagnostic service code if there is a problem with the electronic oven control. See page 22 for further instructions.

The oven control will also beep if you delay too long between programming steps.

TO SET THE ELECTRONIC CLOCK

When your range is initially powered (or when power has been interrupted) the display will flash.

1. Push **CLOCK** button once. Time digits will stop flashing and "Time" will appear in display.
2. Turn **TIME/TEMP SET** knob in either direction for correct time of day Push **SET/CANCEL** button once to set time (this will not cancel programmed time). Time of day will now show in the display.

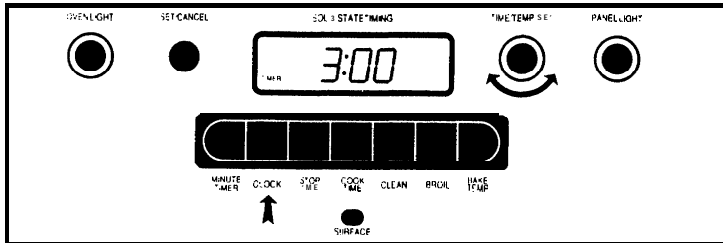

To change the clock time at any time, repeat steps above.

NOTE: This is a 12-hour clock which does not distinguish between AM and PM.

TO SET THE MINUTE TIMER

Use this handy kitchen timer for time baking, **rangetop** cooking and other various household activities.

1. Push **MINUTE TIMER** button once. "TIMER" will show in display

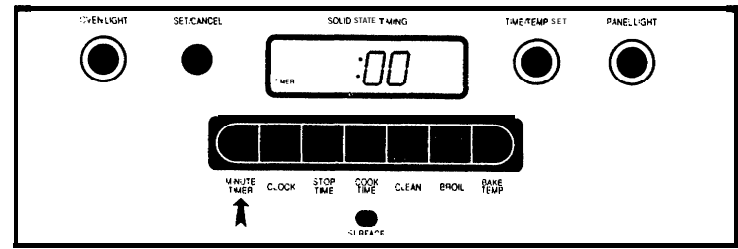

2. Turn the **TIME/TEMP SET** knob clockwise until you have selected the length of time you want. The timer displays in **minutes:seconds** up to one hour and then it displays in **hours:minutes** up to 9 hours and 50 minutes. For example 30 minutes would be **30:00**, and 2 hours and 30 minutes would be **2:30** ('HR' would show also).

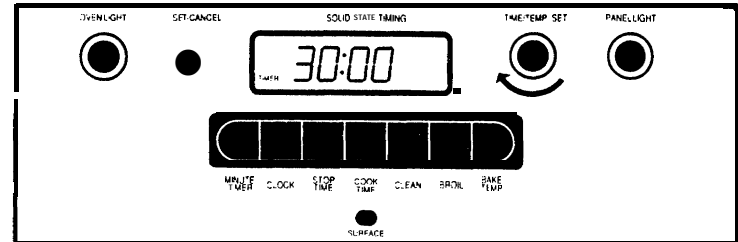

Minute timer will begin to count down in one second (or one minute) increments. Timer can be programmed for a maximum of 9 hours and 59 minutes. "HR" will show when hours have been programmed.

You can add or delete time as necessary by turning the **TIME/TEMP SET** knob in either direction.

3. When time has elapsed, the control will sound three long beeps and then will beep once every ten seconds.
 - Push **CANCEL** button to stop beeping and return time of day to display
4. **To cancel minute timer**, push and hold **MINUTE TIMER** button until time of day shows in display

NOTE: The Minute Timer is only a helpful reminder and does not operate the oven. The timer can be used whether or not the oven is being operated.

*When programming the Minute Timer, the display shows minutes and seconds in the following sequence:

- For settings from 0 minutes to 1 minute 55 seconds, the display will increase in 5-second increments.
- For settings from 2 minutes to 9 minutes 50 seconds, the display will increase in 10-second increments.
- For settings from 10-59 minutes, the display will increase in 1 -minute increments.
- For settings from 1 hour to 1 hour 55 minutes, the display will increase in 5-minute increments.
- For settings from 2 hours to 9 hours 59 minutes, the display will increase in 1 0-minute increments.

HOW TO START RANGETOP COOKING

SURFACE BURNER CONTROLS

The control panel is marked to show which of the four burners each knob controls. These controls have distinct click positions for setting the flame at High, Medium, or Low. This instant flexibility is one of the reasons why good cooks prefer gas. They know that temperatures must adjust exactly and that instant changes are necessary for cooking perfection.

The burner control knobs may also be turned to any position in between the settings indicated to achieve the desired flame settings.

Use the large burners for cooking large quantities of food and the small burners for smaller quantities of food and simmering. Make sure bottom of cookware is clean and dry before placing it over the burner.

Covering cookware can improve cooking efficiency; less fuel is needed and the kitchen stays cooler and cleaner. Also, remember that boiling temperature is fixed by altitude. Food will therefore not cook any faster when more than the amount of heat needed to maintain a gentle boil is applied. The water temperature is the same for a gentle or a vigorous boil. A vigorous boil should be used only when a recipe specifically requires it, otherwise select a heat setting which allows for a gentle boil for more efficient cooking.

Different utensils and different amounts of foods being prepared will affect your choice of heat settings; however, experience will soon acquaint you with these characteristics. Do not cook without burner grates in place. Always cook with burner grates installed properly

REMEMBER:

- Do not use aluminum foil or place foods packaged in aluminum foil directly on the rangetop for cooking.
- Do not put plastic, paper, or cloth items on the rangetop. Such items can burn or melt on contact with hot surfaces.

NOTE: Never allow a pot or pan to boil dry as this can damage both the cookware and the rangetop.

When using woks with ring stands, be certain ring stand sits securely on top of the burner grate. Use the ring which is eight inches in diameter or less. Rings larger than this may not sit securely on top of the burner grate. Flat bottomed woks and stirfry pans work well on the gas burners and eliminate the need for a ring stand.

Which pots and pans to use

For best results, energy conservation, and safety; always use cookware which:

1. Is well balanced and sits well on grate.
2. Has a tight-fitting lid.
3. Is made of a material which conducts heat well.

You will find that your rangetop will serve you best if you remember some of its special features when you start to cook and follow the suggested steps listed below. They can help you avoid unnecessary cleaning and prevent overcooking.

Check to see that the range has been plugged into an electrical outlet and the clock is set to the correct time of day.

Before using the surface burner, follow these basic steps:

- Make sure burner grates are properly in place.
 - Choose appropriate cookware with tight-fitting lids.
 - Make sure bottoms of cookware are clean, dry and smooth to absorb full heat output
 - Center cookware on burner grate.
1. **To light the burner:** Select the appropriate control knob, push the control knob in and turn it fully to the left to the "LITE" position. Listen for a "sparking" sound.
 2. When the burner is lit, slowly turn the knob **clockwise**, stopping occasionally to notice the infinite and precise control you have over the flame height. This is perfect temperature control — the secret of good cooking. Note the height of the flame at each basic "click" position — HIGH, MEDIUM, and LOW
 3. Reset the control knob to adjust flame height as necessary for required changes in cooking. The flame should be just high enough to maintain the cooking speed desired. The flame should NEVER extend beyond the bottom of the pan since it is not safe.

When using high flame, never leave the range unattended. Fat is particularly hazardous since it can become hot enough to ignite.

4. When cooking is completed and entire rangetop has cooled, remove burner grates. Clean rangetop as described on page 15.

Spills such as vinegar, lemon juice, tomato juice and other acidic foods should be wiped up immediately when cool enough to handle; they may leave a light stain if left on a heated surface. Cleaning the rangetop frequently will prevent burn-on of food, stains, and maintain the appearance of the range.

NOTE: The surface burners light automatically by an electric ignitor — no matches are necessary. If a power outage should occur, it is possible to use the surface burners, if care is used. **To light the burner**, hold a lighted match at the head of the burner (part projecting above the rangetop) and turn the control knob to the left to the "LITE" position. Once the burner is lit, adjust the flame to the height desired.

Never attempt to manually light the bake and broil burners!

OVEN HINTS:

- Before oven is turned on and heats, check that oven racks are correctly placed. Oven rack supports on opposite sides of oven provide five rack positions for easy adjustments to any baking or broiling operation.
- Oven racks can be pulled forward to the lock “stops” for safe easy loading and unloading. Racks should have the turned corners in rear.
- Use care when opening oven door — let hot air or steam escape before removing or replacing food.
- Do not let potholder contact hot oven burners in oven if oven rack must be moved while oven is hot.
- Do not place anything directly on burners in the oven or cover oven vent holes in the oven or door.
- Avoid frequent door openings. Use oven light and view food through oven door window.
- For possible pie or casserole overflow, cut a piece of aluminum foil slightly larger than the utensil, turn up edges and place on the rack below. Do not place aluminum foil directly on the oven burners or cover entire rack since this will prevent the oven from functioning properly

CAUTION:

To avoid damage to oven or uneven baking, do not place aluminum foil on oven bottom, on oven bake burner or cover entire oven rack.

- **To remove rack**, pull out to lock “stop” position, then lift up and out.
- **To replace rack**, place on selected rack supports with turned up corners to the rear and push, lifting the front edge slightly to slide past lock “stop.”

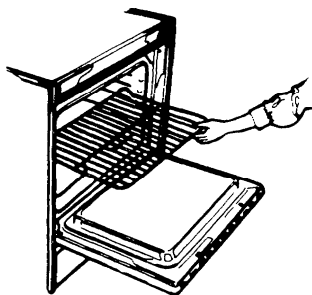

- The oven temperatures for baking range from 170°F to 550°F and can be programmed in 5°F increments.

CAUTION:

The oven burner cannot be used during a power failure. Do not bake when there is a power outage. It will not function.

TO SET OVEN FOR BAKE:

Follow these steps for normal baking. Always place oven racks in position while oven is cool. Use the oven timer as described on page 9, if desired.

For non-preheated baking:

Place food in oven before programming oven control.

For preheated baking:

Program oven control as described in Steps 1 and 2.

1. Push **BAKE TEMP** button once. (Time of day will remain in display)
2. Turn **TIME/TEMP SET** knob clockwise to select the desired oven temperature. The selected temperature will appear in upper right hand corner of the display (Example shows setting of **350°F**)

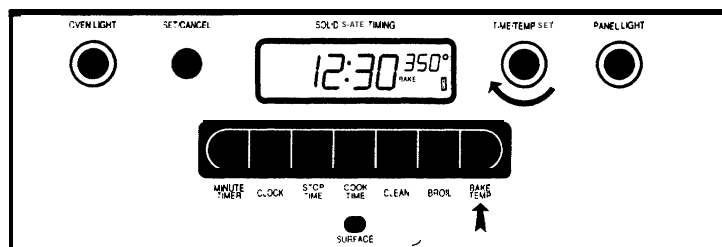

Oven will turn on and temperature displayed will start at 100°F until oven heats above that temperature. Oven temperature will rise in 5°F increments until selected temperature is reached.

3. When baking is completed (or to cancel the program at any time), push **SET/CANCEL** button once to turn oven off. Open door carefully to allow hot air or steam to escape, then remove food. Display will show time of day

IMPORTANT:

Do not move the door lock lever to the “Clean” position (far right) for normal bake or broil operation. Moving the lever to the right may cause the lock mechanism to lock the door in the closed position at normal bake temperature. If lever is in “Lock” position “Door” will appear in display and oven will not operate.

If the door lock lever is accidentally locked and the oven door cannot be opened, turn off the oven controls and wait until the oven has cooled before attempting to move the door lock lever.

Do not force the door lock lever as this may cause permanent damage to the door lock.

TO SET OVEN FOR TIME BAKE:

You can set the oven to automatically start baking now, cook for a selected length of time and automatically stop later. This timed baking is recommended for foods of highly perishable nature, such as milk, eggs, fish, stuffings, poultry and pork.

1. Check to see that oven clock is set correctly. Set correct time if necessary (page 9).
2. Push COOK TIME button once. Display will show "OVEN TIME" and ":00."

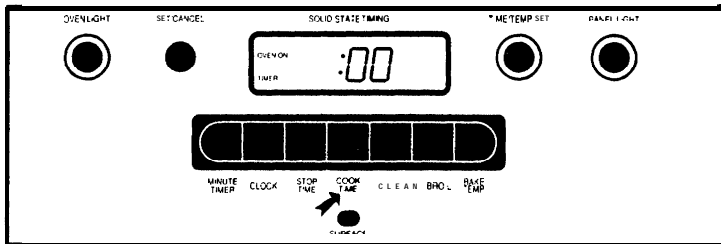

3. Turn TIME/TEMP SET knob clockwise for desired length of baking time (hours:minutes); for example 2:30 for 2 hours and 30 minutes.

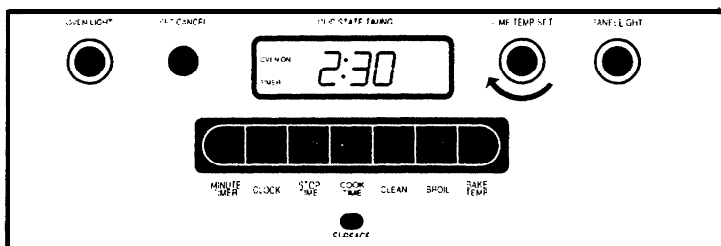

4. Push BAKE TEMP button once. Then turn TIME/TEMP SET knob clockwise to select desired oven temperature. The selected oven temperature will appear in upper right hand corner of the display; for example 350°F.

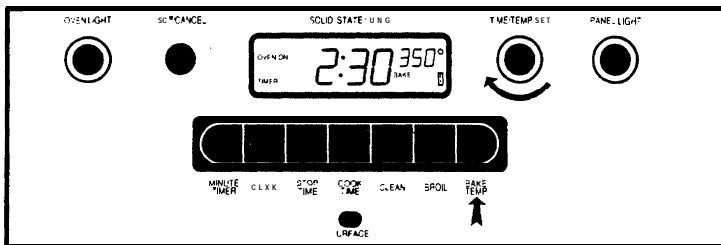

Oven will turn on and temperature displayed will start at 100°F until oven heats above that temperature. Programmed bake time will count down. Oven temperature will rise in 5°F increments until the selected temperature is reached.

- Push CLOCK button to display time of day, Push COOK TIME button to check the amount of baking time remaining.
 - Push and hold in BAKE TEMP button to check programmed oven temperature.
6. After bake time has elapsed, the oven control will beep three times, the oven will shut off automatically and time of day will return to display. Remove food from oven promptly or it may overcook.
 7. Push SET/CANCEL button to cancel program at any time. Time Bake can be set for times ten minutes (:10) up to eleven hours and fifty-five minutes (1155).

CAUTION:

To reduce the risk of food poisoning due to bacterial growth and the production of toxins: never hold meat, poultry, milk, eggs, or fish products more than two hours.-

* The safest foods to use are frozen casseroles and main dishes, or non-frozen soups or casseroles which do not contain meat, milk, eggs or fish.

TO SET OVEN FOR DELAYED TIME BAKE:

You can set the oven to automatically turn on later, cook for a selected length of time and then turn off at the time you want the food ready. This method of timed baking is not recommended for highly perishable foods such as meat, poultry, milk, eggs, and fish products since this may create a health hazard.

1. Check to see that oven clock is set correctly. Set correct time if necessary (page 9).
2. Push COOK TIME button once. Display will show "OVEN TIME" and ":00". (As display in step 2 on the left shows.)
3. Turn TIME/TEMP SET knob clockwise for desired length of baking time (hours:minutes); for example 2:30 for 2 hours and 30 minutes.

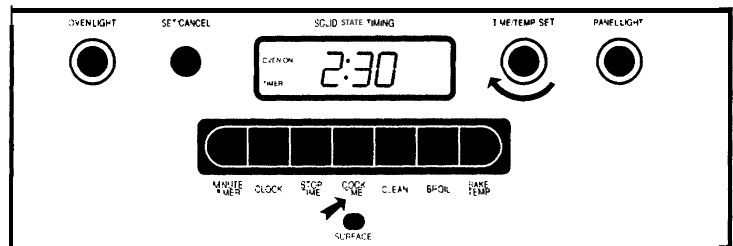

4. Push STOP TIME button once. The display will show the sum of the present time of day plus the selected length of baking time. For example, if the time of day is 1 o'clock and the selected baking time is 2 hours and 30 minutes, the display will show 3:30.
5. Turn TIME/TEMP SET knob clockwise until the time of day when you want food to stop cooking appears in the display. For example 6 o'clock will appear as 6:00. This must be within 12 hours since this is a twelve-hour clock.

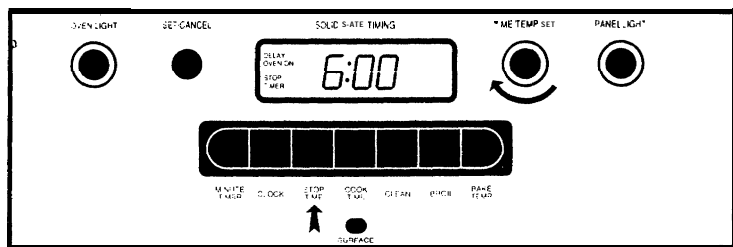

6. Push BAKE TEMP button once.
7. Turn TIME/TEMP SET knob clockwise to select desired oven temperature. The selected oven temperature will appear in upper right hand corner of the display; for example 325°F.

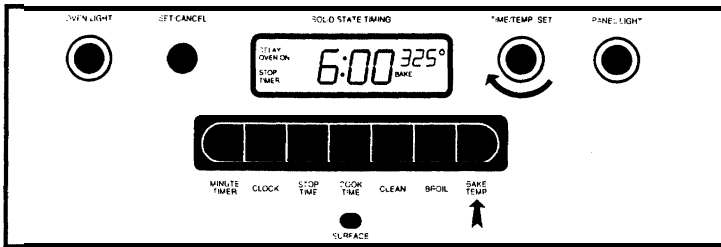

- Push CLOCK button to display current time of day, if desired.
- Push COOK TIME button to check amount of bake time left. Push STOP TIME button to return display to selected stop time.

The oven is now programmed for the delayed start ("DELAY" will show in display). The oven control will calculate the time of day that the oven will turn on automatically to cook the food for the selected length of baking time. (For example, the oven will automatically turn on at 3:30 to cook

for 2 hours and 30 minutes and then shut off automatically at 6:00, the selected stop time.) The oven will beep once when selected oven temperature is reached.

- When stop time is reached, the oven control will beep 3 times, the oven will shut off automatically, and time of day will return to display. Remove food promptly or it may overcook.
- Push SET/CANCEL button to cancel this operation at any time.

CAUTION:
To avoid the risk of fire or property damage: never attempt to broil using the automatic setting. Broiling should be watched and should never be done unattended.

HOW TO ADJUST OVEN TEMPERATURE:

The oven has been calibrated at the point of manufacture. However, if after using the oven for a period of time you wish to adjust the oven temperature to make it bake hotter or cooler, follow these steps. The oven temperature can be set $\pm 35^{\circ}\text{F}$.

1. Push BAKE TEMP button once.
2. Turn TIME/TEMP SET knob clockwise until an oven temperature greater than 500°F shows in the display
3. Immediately push and hold the BAKE TEMP button until "00" appears in the display (approximately 5 seconds).
4. **To decrease the oven temperature** (for cooler oven): Turn TIME/TEMP SET knob clockwise until the negative number (- 05 through - 35 in five degree increments) that represents the $^{\circ}\text{F}$ you wish to select appears. For example, if you want to decrease the oven temperature 20°F you select - 20.

To increase the oven temperature (for hotter oven): Turn TIME/TEMP SET knob clockwise past the negative numbers until the positive numbers (05 through 35 in five degree increments) appear. Select the number which represents the $^{\circ}\text{F}$ you wish to increase the oven temperature. For example, if you want to increase the oven temperature 15°F you select 15.

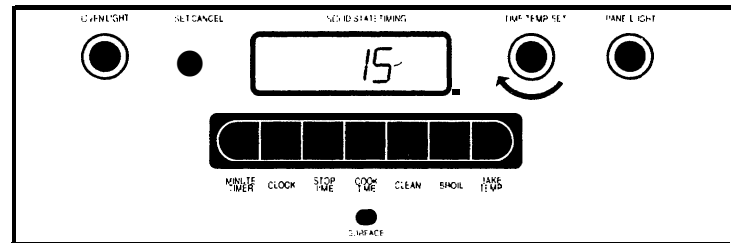

5. Push SET/CANCEL button to enter this new oven temperature adjustment and return display to time of day

Your oven bake and broil temperatures are now adjusted hotter or cooler as you have selected. This temperature adjustment is retained, even through power interruptions, until the oven temperature adjustment is reprogrammed.

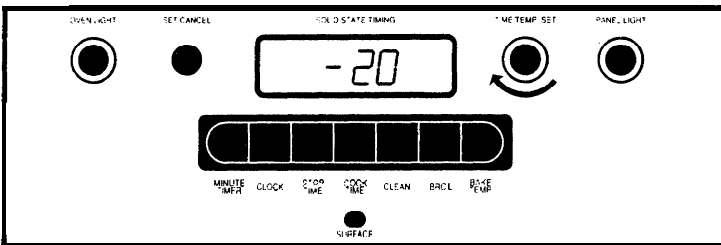

BROILING

Broiling is a quick-cook method that is done with fast, searing heat. It produces meats that are browned or lightly charred on the outside and moist and juicy on the inside,

Your oven is equipped with the Insta-Broil system. Follow the suggested times given in the broiling chart until you familiarize yourself with its operation.

Your oven is supplied with its own porcelain broiler pan and broiler grid. **YOU MUST ALWAYS USE THE BROILER PAN AND GRID SUPPLIED WITH THE OVEN WHEN BROILING.**

BROILING TIPS

- Always use grid with broiler pan as it allows fat to drain

away from meat as it cooks. A small amount of water (about $\frac{1}{2}$ to 1 cup) placed in the broiler pan (under the grid) also helps to reduce spattering and smoking.

- Always start broiling on a cold broiler grid to ensure even broiling. (Do not preheat broiler pan.)
- Do not pierce meat with a knife or fork. This allows the juices to escape.
- Trim the outer layer of fat from steaks and chops and slit fatty edges to prevent the meat from curling.
- Broil food on one side, then season and turn it. Season the second side just before you remove it from the broiler. Do not season meats with salt before broiling. Salt will draw juices from the meat.

- Brush food with **butter** or margarine, if desired. Brush top of chicken or fish several times as it broils. Spray broiler grid with non-stick cooking oil spray to help prevent sticking of fish and poultry. Do not grease a hot grid. Thin fish fillets may not require turning, and fish should always be broiled skin side down.
- Always broil poultry skin side down first, and split and break joints so the meat will lie as flat as possible.
- If putting barbeque or other sauces on the food, do so in the last 5 minutes of broiling to prevent burning.
- Always remove the broiler pan and grid from the oven after broiling is complete. Never leave the pan and grid in a hot oven. Rinsing or soaking the grid and pan while they are still warm will make cleanup much easier.

RACK POSITIONS

The Insta-Broil system uses infrared rays to help cook the food. Because these rays can travel only in straight lines, the effective cooking area of the broiler is reduced when you use the higher rack positions. At high rack positions, the rays cannot reach all corners of the broiler grid, so larger pieces of meat might not broil sufficiently at the outer edges.

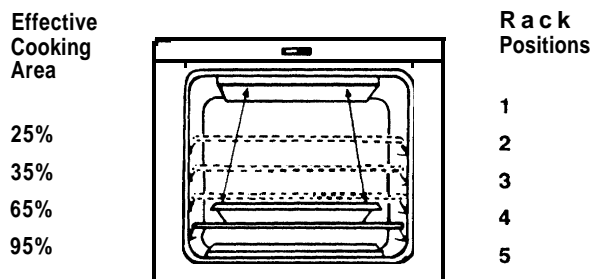

The proper distance from the broil burner is determined by the degree of “doneness” desired, the amount of food being broiled and the overall broiling time. In general, meats are placed closer to the broiler and broiled for shorter periods of time for rare to medium doneness. For **medium-**well to well-done meats, the rack position is lowered and slightly longer broiling times are used. Remember, the closer the meat is to the broiler, the more charred the exterior of the meat will be.

Refer to the Broil Chart for suggestions on rack positions and broiling times. Preheating the broiler is not usually necessary. The time and rack positions in the Broil Chart on page 15 are guidelines for standard broiling performance. If a more rare interior with a more charred exterior is desired for beef steaks, you can move the food to a higher rack position.

A CAUTION:

To avoid the risk of fire, never place foil over the broiler grid. To minimize clean-ups, the broiler pan may be lined with foil, but foil should NEVER be placed to cover top of the grid during broiling; it will trap grease near the broiler element and may cause it to smoke or catch fire.

- Oven door should be closed for all broiling. The Insta-Broil system consumes most smoke and spatter, leaving the kitchen cleaner and cooler.

- Center broiler pan under the broiler on oven rack. Use **minute timer** for convenience in timing.
- Check to see that the oven **vent** is not covered. Do not set or store items in front of the oven vent on top of range.
- If you have a vent hood, turn it on during broiling if desired.

WARNING:

The broiler burner cannot be used during a power failure. Do not broil when there is a power outage, it will not operate.

A CAUTION:

To avoid the risk of fire, never leave range unattended while broiling.

Broiler Pan Position

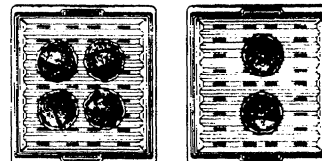

Position broiler pan with short sides parallel to the back of the oven so that it is directly lined up under the broiler burner.

A CAUTION:

To avoid the risk of fire, personal injury or property damage, use the broiler grid only in the proper position as shown above. If it is put in upside down, grease will collect in the rim and could be hazardous. Do not use abrasive cleansers to clean the broiler pan or grid, these may scratch the finish.

TO SET OVEN FOR BROIL:

1. Slide oven rack into correct position. (Other rack should not be between the rack you are using and the oven broiler.)
2. Center food on the broiler grid and set broiler pan on oven rack so that it is centered underneath broiler.
3. Close oven door.
4. Press **BROIL** button once. Time of day will remain in display. Turn **TIME/TEMP** knob to “HI”.

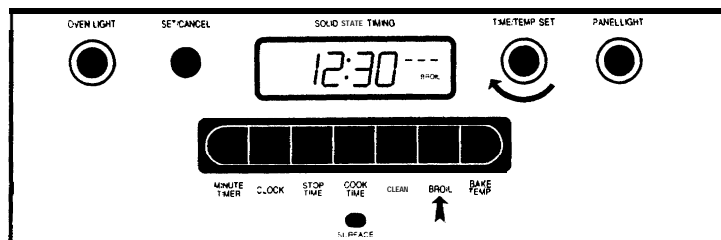

5. Press **SET/CANCEL** button once to turn oven off or to cancel program.

The broil burner will light automatically after 50-60 seconds.

During broiling, the burner will cycle off and on.

“ON” will appear in display indicating the broil burner has turned on. The broiler (upper) burner operates alone for broiling.

Use the chart suggestions below for approximate broil times. Use the minute timer to assist you when **broiling**. Never leave broiler unattended.

Use care when placing or removing broiler pan from oven since the broiler is very hot. Fatty meats and pot holders too close to the broiler flame can ignite.

For preheated broiling:

Leave oven door closed for amount of time suggested in the recipe. If recipe calls for preheated broiling **but does** not give a preheat time, try three minutes.

1. Press BROIL button once. Close oven door.
2. Once broiler is preheated, center broiler pan under the broil element on the suggested rack. Close oven door.
3. Use minute timer; if desired, as instructed on page 9.
4. Press SET/CANCEL button once to turn oven off when broiling is completed or if a programming **error** has been made. Remove broiler pan from oven. . . if pan and grid are left in heated oven they will be **more** difficult to clean. See page 20 for further instructions on cleaning broiler pan and grid.

BROIL CHART

The following chart contains suggestions for broiling foods on the hi setting. Times are approximate since factors such as food thickness and initial food temperature affect length of broiling. Be sure to center food and broiler pan underneath broiler for even heating. Watch broiling carefully to prevent overcooking.

Food	Quantity and/or Thickness	Doneness	Rack Position*	First Side (Minutes)	Second Side (Minutes)	Comments
Hamburgers	4 patties 1/4 to 1/2-inch thick	Medium to Well Done	3	5-7	3-4	
Beef Steaks	4 Ribeye steaks 1/2 to 1-inch thick	Rare	2	4-5	3-4	Slash fat to prevent edges from curling. Satt meat after broiling to prevent drying meat out.
		Medium	3	6-8	3-5	
		Well Done	4	10-12	5-7	
		Rare	3	6-8	2-4	
2 T-bone steaks 1 1/4 to 1 1/2-inch thick	Medium	3	8-10	4-6		
	Well Done	4	10-12	7-9		
Chicken Breasts	2 Chicken breasts (skinless, boneless)	Well Done	2	5-7	3-4	Spray grid with non-stick cooking spray if desired.
Fish	Fillets (3/4-inch thick) Fillets (1/2 to 3/4-inch thick)	Well Done	2	2-3	1-2	Spray broiler grid with non-stick cooking spray to prevent sticking. Handle and turn carefully.
			2	3-6	3-4	
Pork Chops	2 (1/2 to 3/4-inch)	Well Done	3	6-8	3-5	Slash fat to prevent curling. Meat is done when it is no longer pink and juices run clear.
Lamb Chops	2 lamb chops	Medium to Well Done	4	10-12	4-6	Slash fat to prevent curling.
Ham Slice	1 or 2 (1/4 to 1/2-inch thick)	Serving Temperature	2	2-4	2-3	Spray broiler grid with non-stick cooking spray to prevent sticking.
Grapefruit and Tomato Halves	1 or 2 grapefruits or tomatoes, halved (at room temperature)	Serving Temperature	4	7-9	—	Top grapefruit with brown sugar. Top tomato with grated Parmesan cheese.

*Rack Positions — Rack 1 is at the top of oven and Rack 5 is at the bottom of the oven (as shown on page 14).

HOW TO CLEAN THE RANGETOP

A clean **rangetop** is an asset not only to an inviting kitchen but also to an energy-wise pocket book. It is important to keep your **rangetop** clean.

A little regular care will keep your range like new. Daily care will prevent stains from becoming cooked on and will avoid a major cleaning job. For best results, clean after each use.

TO SAVE ON CLEAN UP TIME:

- Before cooking, make sure bottom of cookware, burner grates and **rangetop** are clean and dry.
- Eliminate boilovers and spatters by selecting correct heat settings and using cookware large enough to accommodate food and liquid.
- Use a spatter shield when shallow frying.
- Clean after each use to prevent stains and spatters from cooking on.

CAUTION:
Do not use cleaners on any hot surface. Any resulting fumes can be hazardous. Wait until **rangetop** has cooled before cleaning.

When cleaning.. .
NEVER mix cleaning products



NO!

CAUTION:
To avoid the risk of personal injury, all controls MUST be in the OFF position and rangetop cool before attempting the following:

DAILY CARE:

After the **rangetop** has cooled, remove grease and moisture deposits before using the **rangetop** again. This will help to prevent soil build-up. Wipe **rangetop** with a sponge or cloth dampened with soap and water. Rinse and dry.

To clean the burner grates and burner caps, remove by lifting off. Wash with mild detergent or cleanser such as Soft Scrub® (original, non-bleach formula) and nonabrasive plastic scouring pad such as a Tuffy® plastic mesh ball or Dobie® cleaning pad. Always rinse well and dry thoroughly with soft cloth before replacing.

Avoid abrasive cleansers and abrasive pads such as ScotchBrite® scour pads that may scratch any of the **rangetop** surfaces depending on their abrasiveness and the cleaning pressure applied in use.

NOTE: To prevent the possibility of stains (especially caused by acidic foods such as vinegar, sour milk, lemon juice, marinades and sauces with tomatoes) immediately wipe up spills with a dry cloth. Acids can stain even the most stain-resistant materials and finishes if left on a heated surface. When the surface is cool, wash thoroughly with warm soapy water.

Always clean the burner caps after a spill-over. Keeping the burner caps clean will prevent improper ignition and an uneven flame.

Wipe the burner grates and caps following each use with warm soapy water to remove spillover deposits and grease splatters before they get a chance to harden on the surface. This will help prevent more "involved" cleaning later on. If that should become necessary, follow these instructions.

1. Burned-on soil can be cleaned off by soaking the burner caps in warm soapy water and a dishwashing liquid such as "Dove" or "Lux." A dishcloth or non-abrasive pad such as a Dobie® cleaning pad can be used to rub the burner caps after soaking. If stains still remain: Immerse the burner caps in a hot solution of 2 table-spoons of "Dip It" per quart of boiling water. Soak for 20 minutes (be sure the liquid covers the caps.) Remove burner caps, cool slightly and rinse thoroughly with cold water. Be sure solution is completely rinsed off both sides of the burner caps. Dry thoroughly with soft cloth. Be sure the burner caps are dry, as water lodged in the burner parts may cause an uneven flame, or interfere with automatic lighting.
2. If poor top burner ignition is experienced, it may be due to blocked ignitor slot. When cleaning the burners, pay particular attention to cleaning the small slot by the ignitor. (See Figure 1.) If the slot becomes soiled or clogged, use a cotton swab or a soft cloth to clean the area. For cooked-on soil, use a medium- to stiff-bristle toothbrush. Do not use hard or sharp objects to clean ignitor slot. Do not use cleaning solutions. Remember, do not change the size or shape of this part, or ignition may be affected. Clean ports using same instructions as ignitor slot.

The ignitor slot should remain clean as long as burner cap is sealed properly on burner. Occasionally check burner cap to make sure it is level and covers burner completely.

Gas must flow freely through the ignitor slot for the burner to light properly. This area must be free of any soil and be kept protected from **boil-overs** and **spill-overs**. ALWAYS keep the burner caps in place whenever a surface burner is in use.

3. To replace the burner caps, position them centrally over the burner body. Make sure that the locating pegs fit into the recess in the underside of the caps. The caps must be correctly seated on the burner body for proper operation of the burner. (See Figure 2.)

The bottom areas of the burner grates (and caps) are not covered by porcelain enamel and therefore should be dried thoroughly to prevent rusting. Also, due to the glass-like nature of enamel, there may sometimes be chipping at the prong area; however, this does not affect the performance of the range.

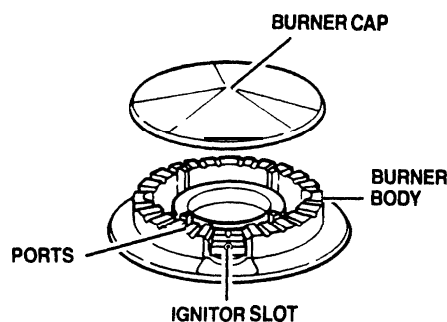

FIGURE 1



FIGURE 2

To clean the control knobs, gently pull them straight off. Wash the face of the knobs using a soft cloth dampened with mild detergent. For tougher soils, use a soft toothbrush. Do not use abrasive cleansers or scouring pads as these can cause scratching. For greasy spatters, use a grease-dissolving cleaner such as Dawn® Dishwashing Detergent. Rinse well and dry thoroughly before replacing knobs.

For care and cleaning instructions of control panel and other range parts, see page 20.

Remember:
Do not use harsh abrasives, chemicals or any of the commercial chemical-type oven cleaners on the interior or exterior of the range.

SELF-CLEANING THE OVEN

During the self-cleaning cycle, extremely high temperatures are generated inside the oven that cause food spills and splatters to decompose into tiny particles of ash that are easily wiped away with a damp cloth. Cleaning can begin and end whenever you choose — even when you are away from home or at night.

BEFORE OPERATING SELF-CLEANING CYCLE:

1. Remove all articles from oven.

Remove all pots, pans, broiler pans and anything else that may be stored in the oven.

Remove oven racks. If the oven racks are left in the oven during self-cleaning, they will permanently discolor and may warp. Therefore, it is recommended that oven racks be removed during cleaning cycle.

Do not obstruct the oven vent located toward back of rangetop.

2. Wipe up large spillovers and excessive grease.

Wipe excessive grease and spillovers from bottom of oven. Heavy spillovers that can be readily wiped up should be removed from the oven before the cleaning cycle is started. These thick spillovers keep the cleaning heat from reaching the bottom of the spillover and could leave small dark uncleaned spots. Removing the heavy spillovers also helps eliminate excessive smoking during the self-cleaning cycle. The lower (bake) burner cover lifts out to make cleaning spillovers easier.

Although the oven bottom is cleaned during the self-clean cycle, it's best to clean up heavy spills as they occur. To remove lower burner cover, grasp cover on each side near the front. Tilt front upward and pull cover toward you. Clean spills, rinse and dry cover thoroughly. To replace cover, insert the two tabs at the rear of the cover into the two slots behind burner area. Lower front of cover down until it is secured in place. Always replace cover before baking, broiling or self-cleaning oven.

3. Wipe soil from oven frame and oven door surrounding gasket while the oven is cool.

The oven front frame and the edge of the oven door that is outside the door seal will not be cleaned by the heat. Do not scrub or clean oven door gasket (D). Clean splatters or spills on oven front frame (A) and oven door surrounding the gasket (B) using a cloth dampened with dish soap and hot water. Also clean the mouth of the oven cavity which is the area up to 2 inches inside the door frame. It's easiest to clean these areas before the self-clean cycle. Use soap and hot water or a non-scratch scouring pad, and rinse well being careful not to allow water to run into vent openings in top of door (C) (See diagram at right). Never use a commercial oven cleaner on or around the self-clean oven. Be careful not to wet down or damage the door gasket in any way

Wipe these surfaces even though they may not appear dirty. The reason is that heat will cause sometimes unnoticeable soil and splatters to bake on and they will be more difficult to remove after the self-clean cycle.

CAUTION:
Do not attempt to clean the oven or broiler burner ignitor assembly. The ignitors are electrically operated and the possibility of electrical shock is present.

IMPORTANT: Do not clean the broiler pan, broiler grid or cooking utensils in the self-clean cycle. Heavy grease buildup on these items can produce smoke and fumes which can be discharged into the kitchen. Also, high cleaning temperatures can cause damage to cooking utensils.

Do not use commercial oven cleaners or harsh abrasives on the self-cleaning oven since this could damage the porcelain finish. All surfaces can be washed safely with soap and hot water. This can be done to minimize over-all cleaning. To retain the original appearance, rinse and wipe the surfaces dry after washing.

Areas to clean before self-cleaning oven.

- A** Oven Front Frame
- B** Oven Door Outside of Gasket
- C** Vent Openings in Door
- D** Oven Door Gasket (Do not clean.)

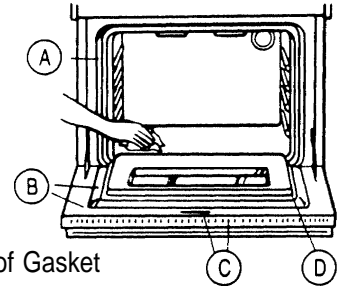

CAUTION:
To Avoid Damage to the Oven:
Do not use chemical oven cleaners in the oven. If cleaners are not entirely removed (they are not always visible), they may have a reaction with oven interior at the high temperature of the self-clean cycle, causing etching of oven interior.

OVEN SELF-CLEANING HINTS:

- A convenient time to self-clean the oven is in the evening when normal oven use is completed.
- It is normal to notice a slight amount of smoke escaping around upper part of door during self-cleaning when there is heavy spill-over. Excessive smoke may indicate excessive spill-overs have not been wiped up or there may be a faulty gasket which should be checked by an authorized service person.

- The oven should be cleaned before it gets “excessively dirty” — which means something different to every cook! The self-clean cycle is preprogrammed for 3 hours which cleans normal soil in your oven. If your oven is excessively dirty, make sure large spills are wiped up. If the oven is not clean after one cycle, repeat cleaning cycle.
- Make sure oven light is off before setting oven for self-cleaning. Also, never self-clean oven if glass light cover is removed or broken.
- Keep the kitchen well ventilated during the self-clean cycle.

CAUTION:
To avoid the risk of burns, do not touch areas above the oven door and around the oven vent (cover vent is located in center of backsplash). These areas become hot enough to cause burns during the self-clean cycle. Do not store or set items in front of oven vent since this area can become extremely warm.

TO SET THE SELF-CLEAN CYCLE TO START NOW:

Make sure you have read and followed the instructions outlined in the previous section “Before Operating Self-Clean Cycle.” Check to see that the clock is set at the correct time of day (see page 9).

1. Slide the Door Lock Lever to the right as shown below. The lever must be all the way to the right for self-cleaning to take place. If it is not “DOOR” will appear in display,

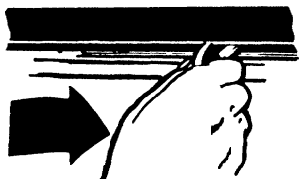

2. Push CLEAN button once. “CLEAN TIME” and “3:00” will appear in display. Three hours of clean time has been preprogrammed for you.

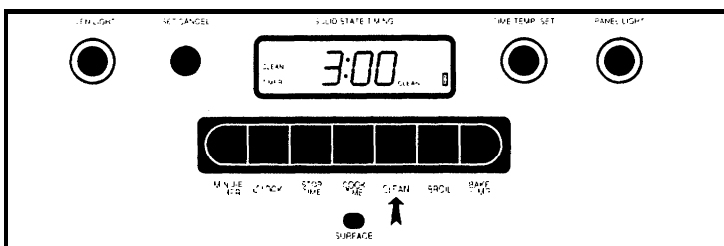

The cleaning time in the display will count down. Press the STOP TIME button to see the time of day when clean cycle will be finished, then press CLEAN button to return display to show remaining clean time.

TO SET THE SELF-CLEAN CYCLE TO START LATER:

1. Check to see that oven clock is set correctly (see page 9) and the steps for preparing the oven prior to self-cleaning have been followed.
2. Slide the Door Lock Lever to the right as shown at left. The lever must be all the way to the right for self-cleaning to take place.
3. Push CLEAN button once.
4. Immediately push STOP TIME button once. Then immediately turn TIME/TEMP SET knob clockwise to the time of day when you want the self-clean cycle to be finished (this time must be at least 3 hours past the current time of day). The oven control will automatically calculate the time of day the self-clean cycle will start.

For example, if the current time of day is 4:00 p.m. and you want to set the self-clean cycle to be finished at 9:00 p.m., set the stop time for 9:00. The oven will automatically turn on at 6:00 p.m. and then turn off at 9:00 p.m.

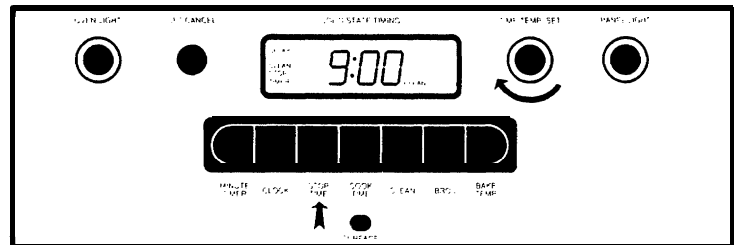

The oven is now set for a delayed start. “DELAY CLEAN” and “STOP TIME” will appear in display. The oven will not turn on until the clock reaches the calculated start time. The “ON” will appear in the display when the self-clean cycle starts.

NOTE: Since this is a twelve-hour clock, the maximum amount of time you can program for delay is 12 hours.

WHAT HAPPENS DURING SELF-CLEAN CYCLE:

Once the oven has been programmed to start self-cleaning or when the calculated start time for a delayed self-clean cycle has been reached, the oven ON indicator light will turn on indicating that the oven is in operation. As soon as you finish programming, the control lock will light in the display, the LOCK indicator light will come on and the door lock lever will not be able to be moved. This is a safety measure which prevents the oven door from being opened under high temperature conditions.

- The temperature will continue to rise to about 900°F where it will stay for the remainder of the cleaning time. (Note: The first few times the self-cleaning system is used, there may be minor smoking and a slight odor as the oven insulation “cures.” This will disappear after the first few cleaning cycles.)
- The oven vent exhausts vapor and warm air during self-cleaning cycle. It should always be left unobstructed.
- You may notice some wisps of smoke from around the door or oven vent at the beginning of the cleaning cycle. The vapor and smoke generated during the self-cleaning cycle is catalytically cleaned before being discharged into the room.

TO INTERRUPT OR CANCEL SELF-CLEAN CYCLE:

1. Push SET/CANCEL button once. This cancels all programming functions.
2. Display will return to time of day. Allow oven to cool. If oven is still hot, the door will remain locked (as indicated by "LOCK" in display) until the oven has cooled to a safe temperature. When the oven has cooled for approximately 1 hour, the oven door can be unlocked and opened, allowing warm air to escape.

Never force the door lock lever. Wait until it moves easily



CAUTION:

AVOID TOUCHING AREAS ABOVE OVEN DOOR AND IN FRONT OF OVEN VENT (oven vent is located in center of backsplash). THESE AREAS BECOME HOT ENOUGH TO CAUSE BURNS DURING CLEANING CYCLE.

NOTE: IF LOCK LEVER IS NOT IN FULL RIGHT "LOCK" POSITION, "DOOR" WILL APPEAR IN DISPLAY AND CLEAN CYCLE WILL NOT START.

AFTER SELF-CLEAN CYCLE IS FINISHED:

The oven temperature will drop and when a safe temperature is reached and the oven door unlocked, "LOCK" will disappear from the display. Time of day will return to the display.

1. Slide door lock lever to the left. Open oven door carefully. Leave door ajar to finish cooling oven.
2. When oven has cooled completely, remove any ash from bottom of oven with a damp paper towel. If small, dark burned-on spots remain inside the door or in the oven they may require some manual cleaning.
3. Remove any baked-on soil from around oven door and oven frame with damp cloth and cleanser.
4. If oven racks do not slide easily, very **lightly** wipe the sides of the racks with a small amount of vegetable oil after the cleaning cycle is completed. This helps the racks to slide more easily and avoids damaging the porcelain oven interior. Do not put too much oil on the rack sides since this can soil the sides of the oven cavity.

CARE AND CLEANING OF OTHER PARTS

Wash all surfaces frequently with soap and hot water to minimize overall cleaning. To preserve the original appearance, rinse and wipe the surfaces dry-after -washing.

Several different materials have been used in the construction of your range. Each material is well-suited to its specific purpose, but care and cleaning of these materials differ. Some materials are harmed by cleaning agents that work well on others,

Part	Materials to Use	General Directions
Glass Oven Door Front	<ul style="list-style-type: none"> • Glass cleaner, e.g. Windex® • Soap and Water 	Clean with glass cleaner or soap and water. Wipe with lintless cloth or towel. Be careful not to spray cleaner inside vent openings.
Control Panel, Control Knobs and Control Buttons	<ul style="list-style-type: none"> • Soap and Water 	Remove control knobs and control buttons by gently pulling them off. Wipe faces of control knobs and buttons with cloth dampened in warm soapy water, rinse and dry well. To clean control panel surface use a cloth dampened with warm soapy water, rinse and dry. Or spray glass cleaner on a soft cloth and wipe control panel surface. Be careful not to allow liquids or cleansers to run into openings. After replacing control buttons, press SET/CANCEL button and cancel any accidentally entered programs.
Painted & Brushed Aluminum, Porcelain Enamel, Stainless Steel and Chrome	<ul style="list-style-type: none"> • Soap and Water 	Wash, rinse, dry with soft cloth. Avoid abrasive cleansers which might scratch or dull the finishes. Clean regularly when range has cooled.
Storage Drawer	<ul style="list-style-type: none"> • Soap and Water 	Pull drawer out to open position and clean inside.
Bake Burner and Broil Burner		Do not clean the bake burner or broil burner.
Broiler Pan and Grid	<ul style="list-style-type: none"> • Soap and Water • Soap-Filled Scouring Pad • Plastic Scouring Pad 	Drain fat, cool pan and grid slightly. (Do not let soiled pan and grid stand in oven to cool.) Sprinkle on detergent. Fill the pan with warm water. Let pan and grid stand for a few minutes. Scour with non-abrasive pad if necessary. Rinse and dry.
Oven Gasket		Avoid getting ANY cleaning material on the gasket. Do not scrub woven gasket.
Oven Interior Surfaces*	<ul style="list-style-type: none"> • Soap and Water 	Cool before cleaning. Frequent wiping with mild soap and water will prolong the time between major cleanings. Be sure to rinse thoroughly
Oven Racks	<ul style="list-style-type: none"> • Soap and Water 	For heavy soil, clean by hand and rinse thoroughly.

***IMPORTANT:** To prevent the possibility of stains, spills of marinades, fruit juices, vinegar, sour milk and basting materials containing acids which may cause discoloration should be wiped up immediately. Use care not to touch any hot portion of the oven. When the surface is cool, clean and rinse. Acids can stain even the most durable materials and finishes.

REMOVABLE OVEN DOOR

The oven door is removable for more convenience when cleaning up large spills or cleaning the back of the oven. Do not immerse the oven door in water when cleaning.

TO REMOVE OVEN DOOR:

⚠ CAUTION:
Oven door is heavy.

1. Open door to first stop position (open approximately 4 inches).
2. Grasp the door firmly at each side and lift upward and off the hinges.

TO REPLACE OVEN DOOR:

1. Align door with hinge arms.
2. Slide door down and into place. Be sure door is all the way down on hinge before closing, to prevent the possibility of chipping porcelain or scratching chrome.

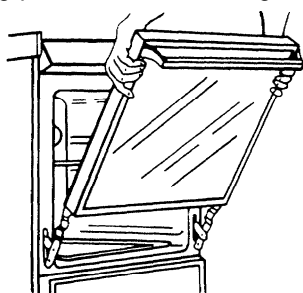

TO REPLACE OVEN LIGHT:

⚠ CAUTION:
To avoid the risk of burns or electrical shock:

- Disconnect the electric current to the appliance at the wall outlet fuse or breaker box.
- Wait until the oven light bulb is cool.

USE CAUTION WHEN REPLACING THE OVEN LIGHT.

1. Turn the glass cover counterclockwise to remove. Remove the old bulb in the same manner. (A dry oven mitt or cloth will protect against broken glass.)
2. Replace with a 40-watt appliance bulb, rotating it clockwise.
3. Replace the glass cover by rotating it clockwise.

TO REPLACE BACKSPASH FLUORESCENT LIGHTBULB:

- Flip up backsplash cover by firmly grasping with hands and pulling upward.
- Hold tube on both ends and rotate top toward back of range. Lift out.
- Slide tube pins located at each end of replacement bulb tube into lamp holder slots. Push down slightly and roll toward you until it clicks into the socket. Close backsplash top cover.

STORAGE DRAWER

The storage drawer is for storing pots and pans. The drawer can be removed to make it easier to clean under the range. Use care when handling the drawer.

TO REMOVE THE STORAGE DRAWER:

1. Pull the drawer straight out to the first stop. Lift the front and pull out to the second stop.
2. Let the front of the door rest on the floor. Place your hands toward the back of the drawer and lift it out.

TO REPLACE THE STORAGE DRAWER:

1. Place the set of rollers on the drawer behind the set of rollers on the oven. (As shown in figure 2)
2. Line the guides up with each other and push the drawer back into position.

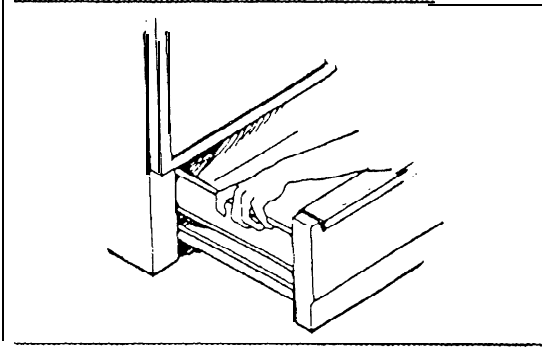

Figure 1

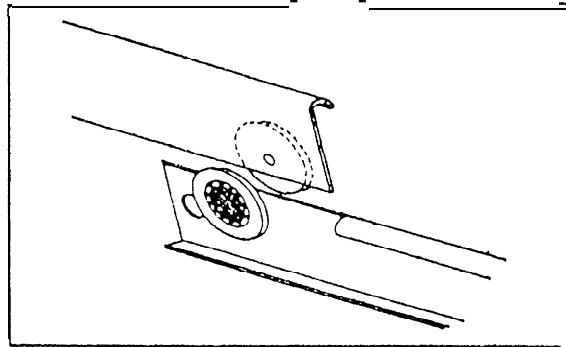

Figure 2

COMMONLY ASKED QUESTIONS

1. Q. What cookbook is suggested for use with my new range?

A. Range temperatures are standardized. For instance, 350°F will be consistent from one oven brand to another. We suggest consulting a basic cookbook such as *Betty Crocker* or *Better Homes and Gardens*. These cookbooks contain basic baking and cooking times and temperatures.

2. Q. I've put an oven thermometer in my oven and noticed it does not maintain a constant temperature. Do I have a problem?

A. To maintain a temperature for baking, your Amana oven will cycle off and on. You may see a "swing" in temperature of as much as + 25°F, but the average will be the temperature desired. This temperature cycling is considered a normal procedure in range operation.

3. Q. When broiling, is it necessary to always use a grid in the pan?

A. Yes. The grid suspends the meat over the pan. As the meat cooks! the juices fall into the pan. Drippings are protected under the grid and stay cooler, thus preventing excessive spatter and smoke.

4. Q. Must the clock be set on correct time of day when I wish to use the Time Bake or Delayed Time Bake features?

A. Yes. Set the clock for the correct time of day to ensure proper operation of timed functions and satisfactory results.

5. Q. Can I use the Timer during oven cooking?

A. The Timer can be used during any cooking function and is especially handy when baking or broiling. The Timer can also be used to time other kitchen activities even while you are using the automatically timed functions.

6. Q. If my range clock is not working, can I still self-clean my oven?

A. No. Your oven control uses the oven clock to help start and stop your self-clean cycle.

7. Q. Should there be any odor during the self-clean cycle?

A. Yes. There may be a slight odor during the first few cleanings. Failure to wipe out excessive soil might also cause an odor when cleaning.

8. Q. What should I do if excessive smoking occurs during cleaning?

A. This is caused by excessive soil, and you should press the SET/CANCEL button to shut oven off. Open windows to rid room of smoke. Allow the oven to cool and unlock before attempting to open the door. When oven has cooled, wipe up the excess soil and reset the self-clean cycle.

9. Q. Is it normal for my rangetop to get warm during use?

A. The rangetop may become warm to the touch while the range is being used to bake, broil, or self-clean. The longer the range is operated! the more the heat can be conducted to the rangetop. The oven vents out over the rangetop so do not set or store items in front of the oven vent.

SERVICE TONES

If the oven control sounds a series of short, rapid beeps and the display shows a diagnostic service code (F0-F9), there may be a problem with the electronic oven control.

If this has occurred while you were programming the oven control, push the CANCEL button and try reprogramming the oven control. If the service tone continues and doesn't stop within 16 seconds, push CANCEL button. If you are unable to cancel the beeping with the CANCEL button, unplug the range or disconnect the circuit breaker. Next, contact your nearest authorized servicer and indicate which diagnostic service code has appeared in your oven's display

Each diagnostic service code indicates which part of the control or oven needs to be checked by the servicer.

F0 — indicates a problem with the CANCEL button operation. *

F1 and F7 — indicates a possible short in the control.*

F2 — indicates an excessively high bake/clean temperature.

F3 and F4 — indicate a problem with the oven's temperature sensor. The service tone will occur again when oven is used for bake, broil or clean operations until checked by a servicer.

F5 and F8 — the control will reset to a non-bake mode. The service tone will occur again when the oven is used for bake, broil or clean operations.

F6 — the control will not sound a service tone when this code appears in the display. The control may reset to a non-bake mode.

F9 — indicates the door lock mechanism may need to be checked by a servicer. *

Fd — indicates bake or broil elements need to be checked by a servicer. The oven control will reset to a non-bake mode.

If the electronic control should ever flash through different features! you have probably programmed the sales-demo mode accidentally. Press the CANCEL button to clear the display and return to the time of day.

*If any of these service codes appear in display, the range must be unplugged or power must be disconnected until it has been serviced. Help the servicer give you prompt service by informing them which service code has appeared in your display. See page 23 for more service information.

BEFORE CALLING FOR SERVICE

Make sure you have understood and followed instructions in your Use and Care Manual. Avoid unnecessary service calls for difficulties that are not a result of defective workmanship or materials. You will be charged for a service person's travel expenses and labor, even though the product may be under warranty, if the difficulty is not caused by workmanship or materials, or if that component is considered customer replaceable. The following items are considered customer replaceable: control knobs and buttons which can be removed by pulling off the control shaft, oven racks, light bulb, and burner grates.

- Review use and care instructions.
- Check the suspected defect a second time.
- Check to see that the controls are properly set.

If self-clean cycle does not start:

- Check to see that oven is not set for a delayed start.

If the oven light does not come on, check the following:

- Is the power cord plugged in?
- Is the bulb loose? If necessary, replace the bulb with a 40-watt heat resistant appliance bulb. Do not use an ordinary light bulb.

If the oven does not heat, check the following:

- Is the oven control set to the desired temperature?
- Is the oven control set for "BAKE" or "TIME BAKE"?

If the broiler burner does not light, check the following:

- Are the oven controls set for "BROIL"?

Electrical Failure

- If the top burners on the range will not light, there may be an electrical failure. To check electrical continuity to the range, be certain that the range power supply cord in the rear of the range is firmly seated in the wall socket and that a household fuse or circuit breaker has not blown.

If all electrical connections are all right and no sparking occurs, call your servicer since more than a simple electrical failure is involved. The problem would be that no sparking is occurring and the servicer would have to correct this problem.

Amana's warranty does not cover damage to the product caused by improper connection to an electrical or gas supply. Repair will be authorized only at the owner's and/or installer's expense.

WHEN SERVICE IS REQUIRED

The dealer from whom you purchased the range can give you the name of your nearest Authorized Service Center. Help them give you prompt service by giving them:

1. An accurate description of the trouble.
2. Complete model, serial and manufacturing numbers. To see nameplate open storage drawer. The nameplate is on the right hand side of lower oven frame.
3. Proof of purchase (sales receipt on request).

Repair by an unauthorized servicer that results in subsequent failure will void the warranty. Warranty details are contained in the warranty certificate enclosed with this manual.

Keep an accurate record of any service calls: what was done, who serviced the range, and the date of service.

Amana has a large network of Authorized Service Centers in the US. However, if you should have a service problem that is not resolved locally,

Write: Consumer Affairs Department
Amana Refrigeration, Inc.
Amana, Iowa 52204
or Dial: 1-800-843-0304

Please include the model and serial numbers, date of purchase, and selling dealer.

For quicker service, or for answers to questions concerning product usage, installation or warranty, call:

CONSUMER INFORMATION LINE TOLL FREE



Amana is pleased to offer an important opportunity for long-term service protection on your new Amana appliance. The Asure Extended Service Plan is specially designed to supplement the strong warranty that already accompanies your appliance, and it combines with this standard warranty to provide budget-protecting coverage on your appliance for up to five full years, covering parts, labor and travel charges.

Please contact us at:

Please contact us at:

Amana Refrigeration, Inc.
Consumer Affairs Department
Amana, Iowa 52204
1-800-843-0304

Asure
EXTENDED SERVICE PLAN

